



## SOFTSIDER - DROP DECK

# Softsider



## BUILT STRONGER, TO LAST LONGER

The Strength to weight ratio of Southern Cross Softsider Drop Deck Semi-Trailers provides operators with in-service reliability and a trailer manufactured to cope with Australia's harshest conditions.



### Construction

- High-tensile steel is used extensively throughout the structure to provide maximum strength.
- The entire frame is sand-blasted and prime coated prior to a superior long lasting finish in your companies fleet colours.
- The comprehensive range of suspensions, axles, landing legs, components and fittings are selected for their proven reliability.



Discuss your requirements with our sales staff today. They will help you gain the best value from your new Southern Cross equipment.

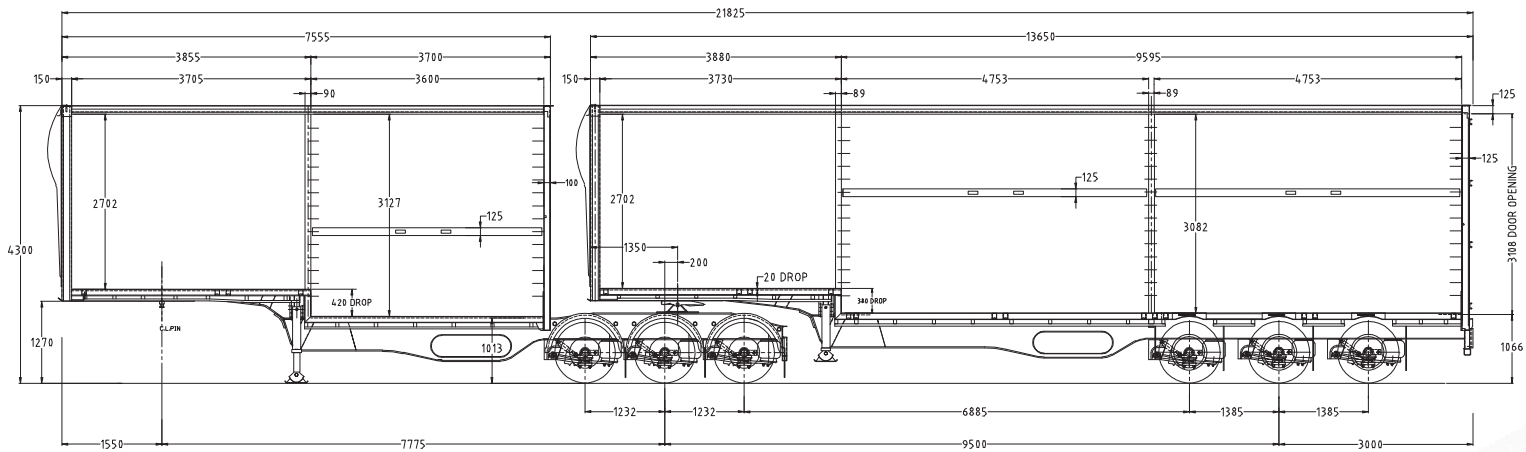

### A-Trailer

Dimensions	
Length	7600mm
Width	2500 mm
Height	4300mm
Construction	
Chassis	High tensile steel I beam design. Heavy duty neck - suit Road Train
Floor	3mm steel chequer plate over RHS floor runners. Many floor options.
Mezzanine Floor	1 x Bottom Deck - fully removable including posts
Rear Wall	FRP Solid rear wall
Coaming	4 inch RSJ coamings, fitted with gate pockets
Curtains	Welded Strap - (Load Restraint Optional)
Curtain Tensioner	Front Tensioner standard. <b>Optional</b> : Rear Tensioner
Gates	1800mm High and level throughout, suspended on straps.
Turntable	Holland, K-Hitch, Jost - 50mm or 90mm
Air Deflector	Full length front wall air deflector fitted
Winches	Six (6) winches in track
Tool Box	<b>Optional</b> : 1 x 1200mm long with stainless 'T' handles
Running Gear	
Suspension	Euro II Airbag, BPW, SAF, TMC
Axles	K-Hitch 20" Parallel bearing axles – standard <b>Optional</b> : Spoke, 10 x stud, 15", 19.5" - BPW, SAF, TMC, Hendrickson
Brakes	ADR brake kit – Drum brakes standard, <b>Optional</b> : Disc brakes and ABS / EBS as required.
Landing Legs	TMC heavy duty landing legs, compensating feet standard
Wheels	10 Stud steel - 285 PCD
Tyres	Full range available as required
Tyre Carrier	Dual cut through main rails, c/w chains
Electrical	
Lights	Narva L.E.D with dual 7 pin & 40 amp plugs standard
Paintwork	
Coaming, Hubs & Toolboxes	Painted in high quality BASF Glasurit 2 PAK paint to clients specified colour
Underside	Hammertone silver standard, 2 PAK optional

### B-Trailer

Dimensions	
Length	13640mm
Width	2500 mm
Height	4300mm
Construction	
Chassis	High tensile steel I beam design. Heavy duty neck - suit Road Train
Floor	3mm steel chequer plate over RHS floor runners. Many floor options.
Mezzanine Floor	2 x Bottom Deck - fully removable including posts
Rear Doors	FRP Double rear doors with anti-racking
Coaming	4 inch RSJ coamings, fitted with gate pockets
Curtains	Welded Strap - (Load Restraint Optional)
Curtain Tensioner	Front Tensioner standard. <b>Optional</b> : Rear Tensioner
Gates	1800mm High and level throughout, suspended on straps.
Air Deflector	Full length front wall air deflector fitted
Winches	Eleven (11) winches in track
Tool Box	1 x 1200mm Long with stainless 'T' Handles
Water Tank	60L plastic
Running Gear	
Suspension	Euro II Airbag, BPW, SAF, TMC
Axles	K-Hitch 20" Parallel bearing axles – standard <b>Optional</b> : Spoke, 10 x stud, 15", 19.5" - BPW, SAF, TMC, Hendrickson
Brakes	ADR brake kit – Drum brakes standard, <b>Optional</b> : Disc brakes and ABS / EBS as required.
Landing Legs	TMC heavy duty landing legs, compensating feet standard
Wheels	10 Stud steel - 285 PCD
Tyres	Full range available as required
Tyre Carrier	Dual cut through main rails, c/w chains
Electrical	
Lights	Narva L.E.D with dual 7 pin & 40 amp plugs standard
Paintwork	
Coaming, Hubs & Toolboxes	Painted in high quality BASF Glasurit 2 PAK paint to clients specified colour
Underside	Hammertone silver standard, 2 PAK optional

SCTEG reserves the right to change specification information without notice, and accepts no liability, either direct or indirect for any loss that may result from the application of this information. Photographs may show equipment that is available at extra cost.